

# The real deal

## Top reliability

SOREDEX introduced DIGORA® Optime, the world's first intraoral imaging plate system in 1994. The reliability of your DIGORA® Optime is built on the longest experience in the industry; know-how and expertise from tens of thousands installations worldwide is cleverly incorporated in this 5th generation system.

## Digital for all intraoral imaging needs

Imaging plates are available for all intraoral applications and patient sizes. Thin, flexible and re-usable imaging plates are easy to handle, resistant to wear \*) and inexpensive to replace. Original, unique SOREDEX® hygiene accessories support asepsis and maximized lifetime of the imaging plates. Optionally available, patented IDOT™ imaging plates have an individual marking visible also on the X-ray image to support self quality assurance.

## Easy to share with multiple users

Standard network (LAN) connection allows one DIGORA® Optime to serve multiple operatory rooms. Network sharing is an effective and economical solution, since images from one DIGORA® Optime can be accessed from multiple locations

\*) Durability of DIGORA® imaging plates has been validated by an independent study (DentoMaxilloFacial Radiology June 2013, www.birpublications.org/doi/abs/10.1259/dmfr.20120353 )

# Technical data

Feature	DIGORA® Optime DXR-60
Technology	Imaging plate (PSP = Photo Stimulable Phosphor plate)
Pixel size (selectable)	30 µm (SUPER RESOLUTION) 60 µm (HIGH RESOLUTION)
Resolution	17 lp/mm
Readout time	5 - 10 seconds (depending on the plate size)
Connection	Standard network connection (Ethernet RJ45)
Dimensions (H x W x D)	152 x 227 x 308 mm (6 x 8.9 x 12,1 ")
Weight	3.5 kg (7.7 lbs)
Operating voltage	100-240 VAC, 50/60 Hz
Operating system	Windows® 7 or Windows® 8

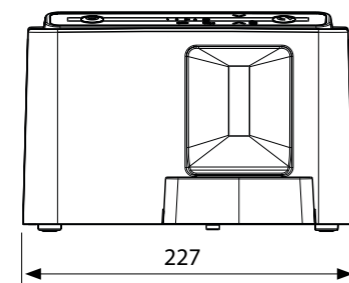
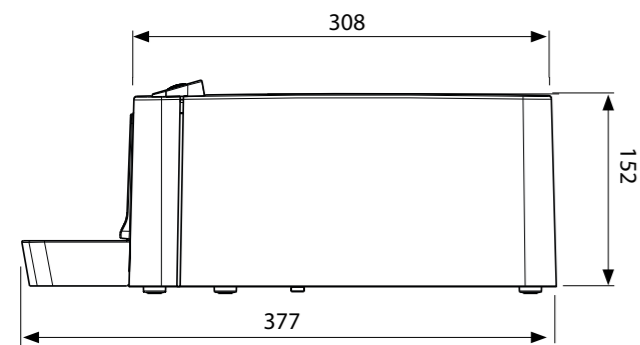

## Head office and factory:

**SOREDEX**  
Nahkelantie 160,  
FI-04300 Tuusula  
Finland  
Tel. +358 10 270 2000  
Fax +358 9 701 5261  
info@soredex.com

## SOREDEX USA

1245 W. Canal Street  
Milwaukee, WI 53233  
U.S.A.  
Tel. +1 800 558 6120  
Fax +1 414 481 8665  
usainfo@soredex.com

## SOREDEX Germany

Schutterstrasse 12  
77746 Schutterwald  
Germany  
Tel: +49 (0) 781 28 41 98-0  
Fax: +49 (0) 781 28 41 98-30  
kontakt@soredex.de

# Digital imaging made easy™

SOREDEX designs, manufactures and markets easy to use and innovative imaging solutions for dental and maxillofacial professionals. SOREDEX portfolio covers wide range of applications from intraoral, panoramic, cephalometric extending to large field-of-view cone beam CT for demanding ENT and CMF diagnostics. Close co-operation with imaging professionals give us deep insight of how to incorporate true diagnostic value to clinical work.

Our products are known for reliability, simplified workflow and excellent image quality. We are committed to fulfill these promises today and in the future.

SOREDEX®/DIGORA®/ Digital imaging made easy™/Comfort Occlusal™/Opticover™/IDOT™ is a registered trademark / a common law trademark of SOREDEX. Other product names and trademarks are the property of their respective owners. CE-marked, NB (CE) number 0537. Electrical safety meets the IEC 60601-1 standard. Manufacturing complies with ISO 13485:2003, ISO 9001:2008, and ISO 14001:2004.

SOREDEX reserves the right to make changes in specifications and features shown herein at any time without notice or obligation. Contact your SOREDEX representative for the most up-to-date information.  
© 2015 SOREDEX

www.soredex.com • www.soredex.de • www.soredex.com/usa

Visit: [www.soredex.com](http://www.soredex.com)

209246-4 Printed in Finland

**SOREDEX**



**DIGORA® Optime**

Intraoral diagnostics.  
In a flash.



## Benefits at a glance

DIGORA® Optime Digital Intraoral Imaging Plate System is easy to use and provides excellent clinical results.

The DIGORA® Optime system makes your daily imaging workflow easier and more efficient. Intuitively easy to learn and simple to use system provides leading clinical results repeatedly and automatically.

With DIGORA® Optime you get it right!



## Cut the cord

### Familiar, film-like workflow

Thin and flexible Imaging plates have no cable; you can position the plates as easy and accurately as film. Digital images are available in seconds automatically, without any additional manipulation.

### Intuitive, simple to learn and use

There is no need to press any buttons during the imaging workflow, just insert the plates, and let DIGORA® Optime to take care of the rest. Correct operation is guided with clear, intuitive indicators and supported by automatic imaging plate detection.

	Optimized	Optimized	Optimized
DIGORA® Optime: Smart Auto-Optimization			
Exposure time:	0,05 sec	0,2 sec	0,4sec
Film or "non-smart" digital system			
	Under-exposed	Correctly exposed	Over-exposed

Auto-optimization for repeatable clinical image quality

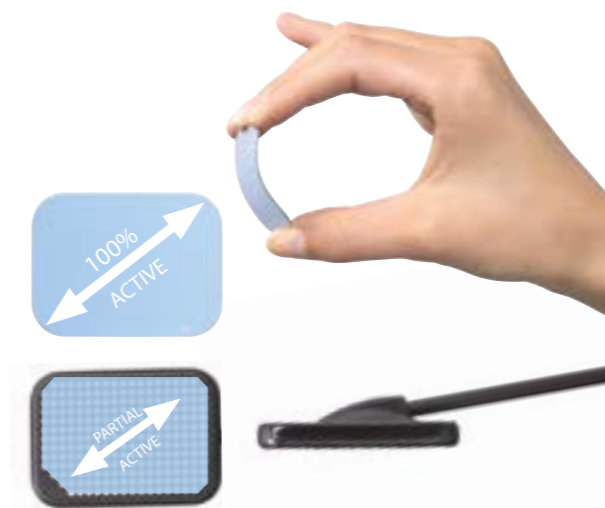

## Smart tool for all intraoral needs

### Repeatable image quality

DIGORA® Optime offers consistent, enhanced diagnostic quality. You receive high contrast images with accuracy to the smallest clinical details - automatically and repeatedly.

### Smart and automated functions

DIGORA® Optime supports error-free operation; the system guides you to use correct exposure settings and does not accept improperly inserted imaging plate. Plates are ready for the next use immediately after processing.

### Comfortable and safe

Thin, flexible and wireless imaging plates are comfortable for the patient. Original DIGORA® hygiene accessories are designed for unique patient comfort and safe use with ease.

0	2	3
	22 x 31mm - Pediatric	27 x 54 mm - Long bitewing
1	2	4C
24 x 40 mm - Pediatric - Small adult - Periapical	31 x 41 mm - Standard adult, bitewing and periapical	48 x 54 mm - Occlusal projection imaging Comfort Occlusal™ 4C: * Uses two size 3 plates * Bite protection & comfort, even for pediatric patients